

-NOTES-

1. MATERIAL: AISI 1015 HR. .59 COLD
DRAWN TO .56 FOR ROLLED THREADS.
2. HOT DIP GALVANIZE PER ASTM SPED A153 (LATEST REV).
3. THREE 5/8" SQUARE NUTS WITH EACH BOLT

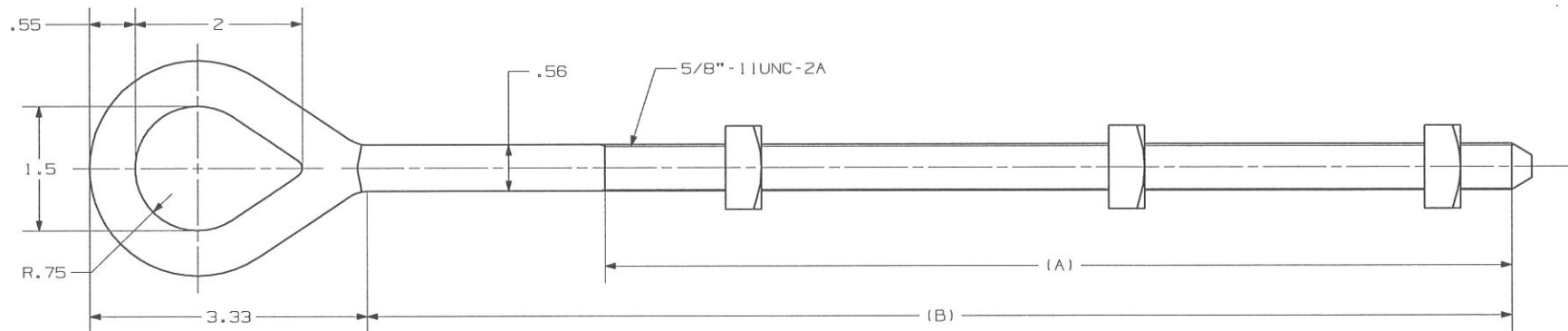

CATALOG NO.	DESCRIPTION	"A"	"B"
19784	D.A OVALEYE BOLT-5/8" X 14"	11	14
19786	D.A OVALEYE BOLT-5/8" X 16"	13	16
19788	D.A OVALEYE BOLT-5/8" X 18"	15	18
19790	D.A OVALEYE BOLT-5/8" X 20"	17	20
19792	D.A OVALEYE BOLT-5/8" X 22"	19	22

LATEST EC NO:		REV.	DATE	CHANGED BY	RESP ENGINEER
-----		K	07/13/12	DMB	KIRK
				DO NOT SCALE THIS DWG	THIRD ANGLE PROJECTION
				150 DUAL DIMENSIONS IN: INCH, MM=MILLIMETER	
DRN BY:	DATE	TITLE:			SIZE
DVH	8-9-04	BOLT, 5/8 OVALEYE DOUBLE-ARMING			C
				DWG NO:	SA19784

CONFIDENTIAL: THIS DRAWING AND ITS CONTENTS ARE CONFIDENTIAL AND THE EXCLUSIVE PROPERTY OF HUBBELL/A.B. CHANCE COMPANY. NO REPRODUCTION, DISTRIBUTION, DISSEMINATION, OR PUBLICATION, IN ANY MANNER, IS PERMITTED WITHOUT THE WRITTEN CONSENT OF HUBBELL/A.B. CHANCE COMPANY. © 2001 HUBBELL/A.B. CHANCE. UNPUBLISHED - ALL RIGHTS RESERVED UNDER THE COPYRIGHT LAWS